

DEVELOPER IS RESPONSIBLE TO PROVIDE 10' MINIMUM CLEARANCE FROM TRANSFORMERS TO ANY COMBUSTIBLE BUILDING STRUCTURE. SEE DET. 4.3

SEE CIRCUIT/CONDUIT & EQUIPMENT PLAN FOR TRANSFORMER SIZES AND OTHER EQUIPMENT LOCATIONS

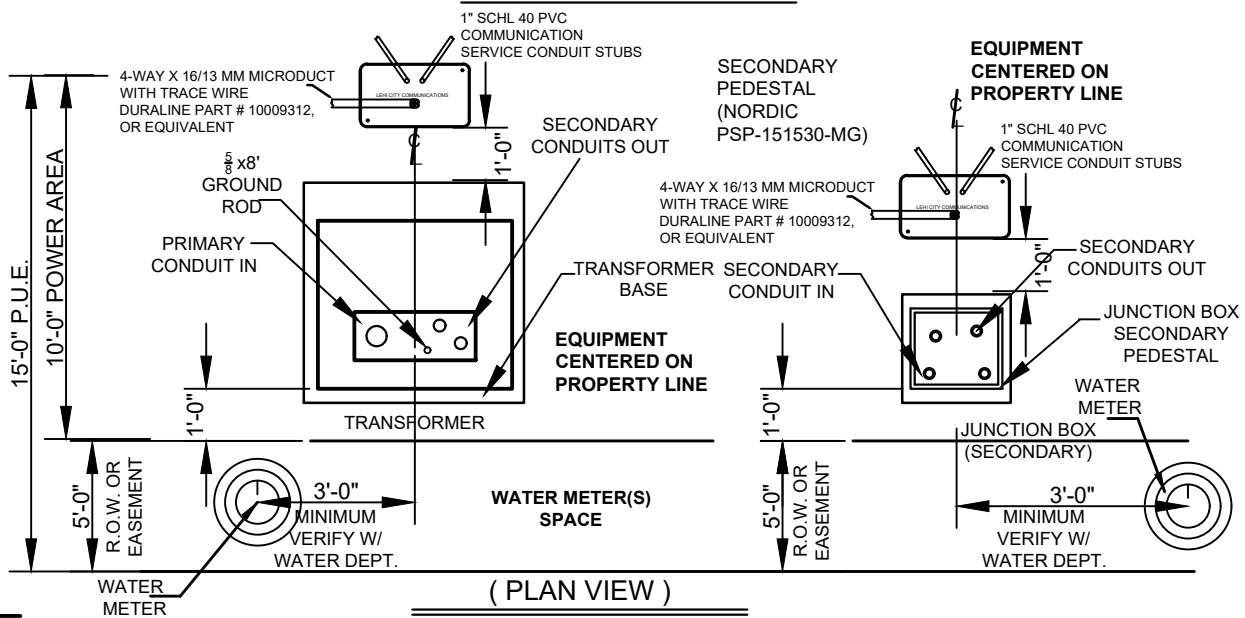
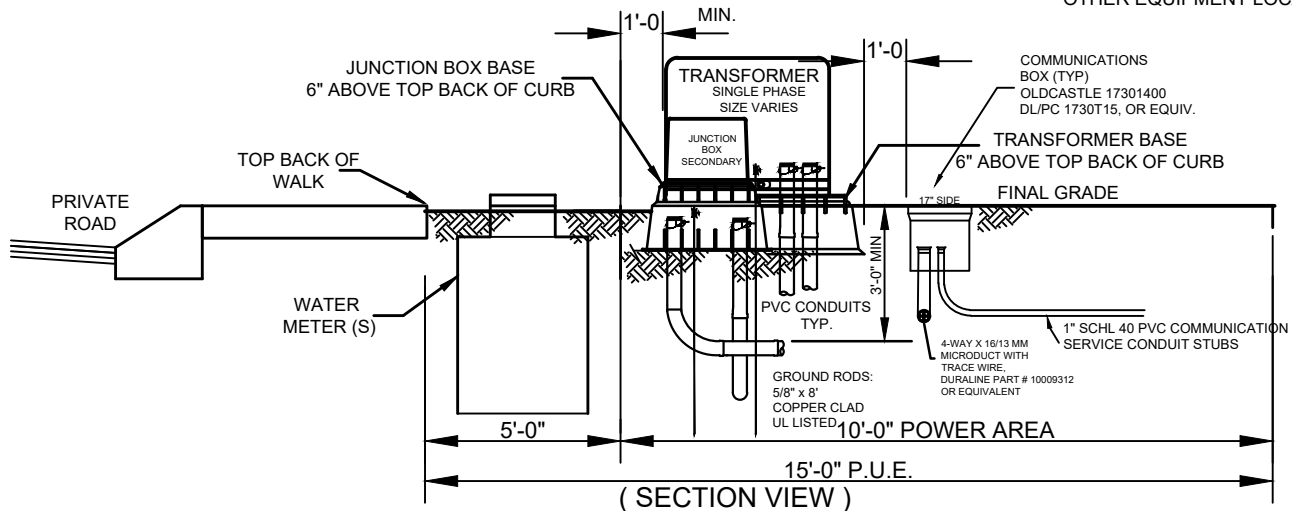

**NOTES:**

1. DEVELOPER/CONTRACTOR SHALL PROVIDE AND INSTALL CONDUITS AND GROUND RODS
2. LEHI CITY POWER SHALL PROVIDE TRANSFORMER BASES, COMMUNICATION BOXES AND SECONDARY JUNCTION BOXES, TO BE INSTALLED BY DEVELOPER/CONTRACTOR.
3. SEE CIRCUIT/CONDUIT PLAN FOR EQUIPMENT LOCATIONS. EQUIPMENT SHALL BE CENTERED ON LOT LINES TO THE EXTENT POSSIBLE. OTHER LOCATIONS AS REQUIRED AND APPROVED BY LEHI POWER.
4. DO NOT OBSTRUCT ACCESS TO POWER BOXES; MAINTAIN 3' CLEAR EXCEPT AS NOTED. PROVIDE 10' CLEARANCE ON ALL CABINET ACCESS SIDES.
5. LEHI POWER SHALL PROVIDE AND SET TRANSFORMERS; PROVIDE, PULL & TERMINATE CONDUCTORS
6. BASES AND BOXES SHALL BE PLACED ON FULL DEPTH COMPACT ENGINEERED FILL - COMPACTED TO 95% MAX DENSITY. EXTEND COMPACTED BASE MATERIAL AS REQUIRED TO MAINTAIN STABLE SUPPORT. REFER TO 4.2.1
7. EQUIPMENT BASES SHALL BE SET LEVEL AND ALIGNED WITH THE WALK OR ADJACENT ENTITIES TO PROVIDE A NEAT APPEARANCE.
8. CONDUIT AND EQUIPMENT SHALL BE PLACED AFTER CURB AND WALK, TO ASSURE CORRECT PLACEMENT WITHIN THE EASEMENT.



**REQUIREMENTS & STANDARDS**  
**TRANSFORMER,  
 JUNCTION BOX &  
 P.U.E. LOCATION**  
**(DEVELOPMENT WITH COMBO CURB/WALK)**

DWG. **4.1.7 A**

REV. 2.00

BY: MRA/BT

DATE: 2/13/24